



BB08-HK BIG BUDDY HEIGHT KIT ASSEMBLY INSTRUCTIONS

ENM-4109-00

ORIGINAL DOCUMENT

Please review all of these instructions prior to assembly.
Please make sure all pieces have been received before attempting assembly.

Tools Required: Two ½" wrenches

Label on Box	Qty	Contents
BB08-HK	2	Riser
	4	Serrated 5/16 – 18 Nut
	4	Serrated 5/16 – 18 Nut

Note: Portions of the assembly procedure require 2 people.

Unpack, identify, and inspect all parts. Report any missing or damaged items.

Height Kit Assembly:

1. Complete assembly of Big Buddy Conveyor Bed per manual.
2. Do not install Chamber. Will be installed later.
3. Remove (4) nuts and bolts from Conveyor Bed. See Figure 1.
4. Install Risers with (4) bolts & nuts to conveyor. See Figure 1.
5. Install Chamber over (4) protruding bolts.
6. Refer back to Big Buddy manual for balance of assembly and operation.

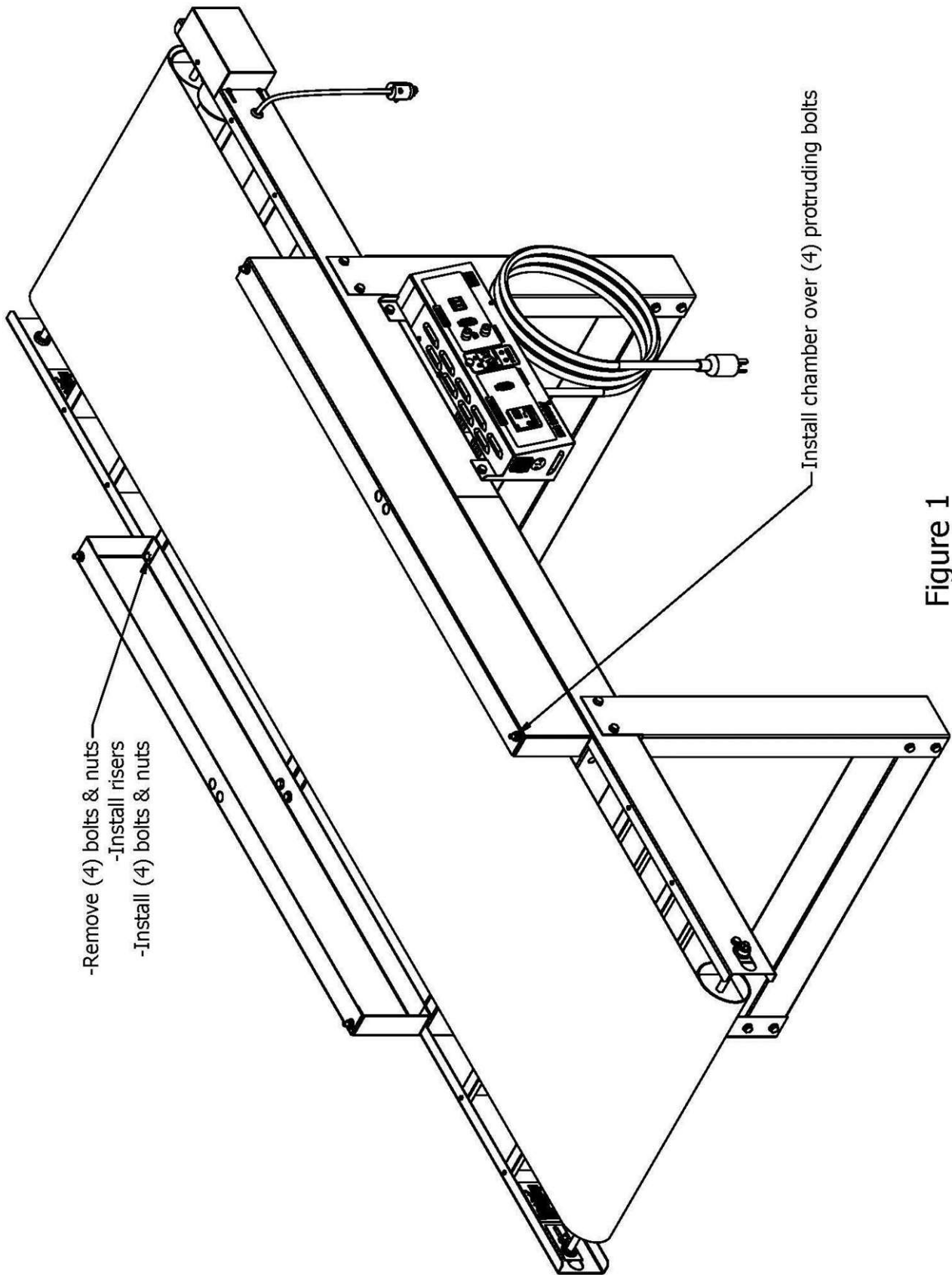

Figure 1